



QUADRALUMEN  
LED by life

# Product TDS

Model No.: QL1001RD

Description: QL LED Round Down Light

Trademark: SPERANZA+

## Product Dimensions

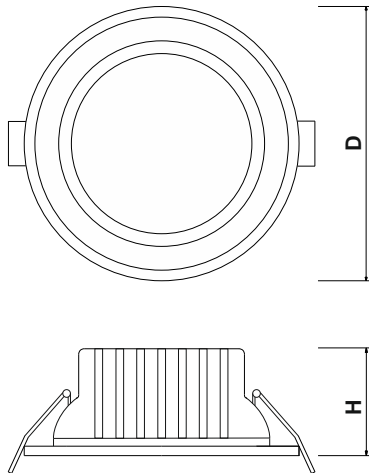

## Product Image



Cat. Ref.	Input Voltage (AC)	System Current (Amps)	System Wattage (Watts)	Power Factor (PF)	THD	Driver Surge Protection	Outer Dia (mm)	Height (mm)	Cut-out (mm)
QL1001RD005W6DL	120-300	0.018	5W	> 0.90	<20%	2.5Kv	145	60	125
QL1001RD007W6DL	120-300	0.026	7W	> 0.90	<20%	2.5Kv	145	60	125
QL1001RD0012W6DL	120-300	0.045	12W	> 0.90	<20%	2.5Kv	145	60	125
QL1001RD0015W8DL	120-300	0.056	15W	> 0.90	<20%	2.5Kv	196	65	174
QL1001RD0018W8DL	120-300	0.067	18W	> 0.90	<20%	2.5Kv	196	65	174
QL1001RD0021W9DL	120-300	0.078	21W	> 0.90	<20%	2.5Kv	240	67	212
QL1001RD0024W9DL	120-300	0.09	24W	> 0.90	<20%	2.5Kv	240	67	212

LED Type	LED Make	Secondary Optics	CRI	Optics Efficacy
0.5W SMD	NICHIA/ Edison	Acrylic Diffuser	> 80	>90

Main Housing/Control gear	Mounting Type	Driver Provision	Powder Coating	IP Protection-Complete Luminaire
Al ,High Pressure Die Casting	Recess Type	Provided Externally	White	IP20

### Area of applications-

Residential, Factories, Business Centres, Offices, School & College, Café & Restaurants, Shopping Arcades, Hotel & Resorts, Theatres, Retail Shops, Modern Retail, Hospitals, IT Centres, Laboratories